

Knives

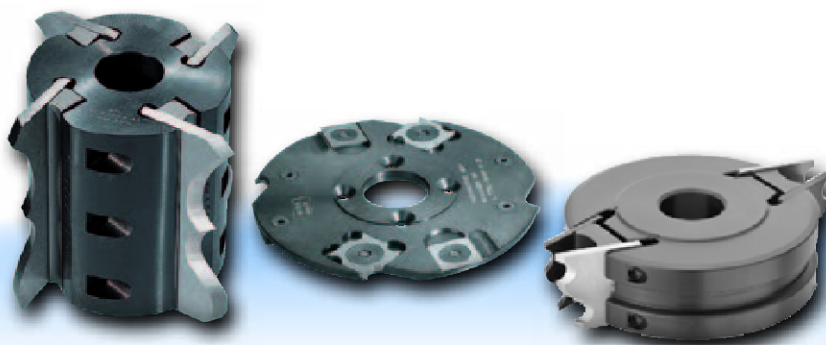

Content

Knives

Product category	Page
Planer knives	358-365
Turn-over knives	366-380
Blanks with back tothing	381-388



61030 | Planer knives 30x3

Quality HS 18%, HW

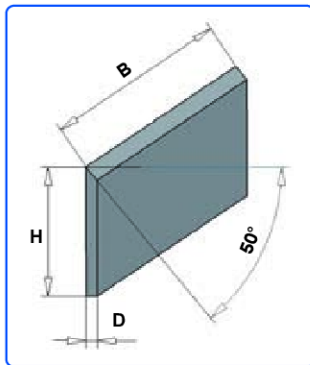

Application: HS 18% = For soft wood and hard wood
 HW-tipped = For hard wood, laminated wood

Design: Ground ready for use
 Packing unit 2 pcs
 Prices are indicated per piece

Width mm	Height mm	Thickness mm	Order No. HS 18%	Price [PG 02]	Order No. HW	Price [PG 02]
80	30	3	10013223		10013895	
120	30	3	10013480		10007302	
130	30	3	40015586		40015651	
150	30	3	10007285		10009176	
180	30	3	40015587		10013901	
190	30	3	40012338		10100358	
210	30	3	40000391		10007309	
230	30	3	10007289		10007310	
250	30	3	10022254		10007312	
260	30	3	10021671		10017859	
270	30	3	10106511		10110494	
300	30	3	10009356		10007313	
310	30	3	10009314		10009218	
350	30	3	10023659		10007315	
400	30	3	10013387		10007317	
410	30	3	10009322		10007319	
450	30	3	40000404		10007321	
500	30	3	10028612		10041808	
510	30	3	10024704		10007324	
520	30	3	10020417		10041809	
530	30	3	40000407		10009411	
610	30	3	10013161		10024127	
630	30	3	10024703		40003161	
640	30	3	10009380		10007329	
710	30	3	40009499		10017858	
810	30	3	10022779		10007331	

61030 | Planer knives 35x3

Quality HS 18%, HW

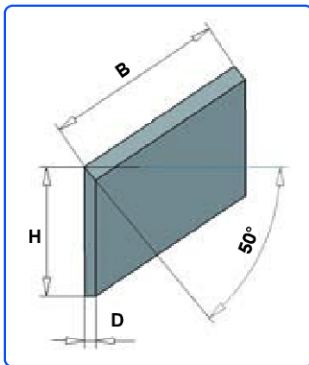

Application: HS 18% = For soft wood and hard wood
 HW-tipped = For hard wood, laminated wood and panel material

Design: Ground ready for use
 Packing unit 2 pcs
 Prices are indicated per piece

Width mm	Height mm	Thickness mm	Order No. HS 18%	Price [PG 02]	Order No. HW	Price [PG 02]
250	35	3	10009292		10009196	
260	35	3	40000592		10041812	
270	35	3	10106280		10110496	
300	35	3	10029021		10041813	
310	35	3	10022846		10026495	
350	35	3	10009319		10009223	
400	35	3	10024662		10007318	
410	35	3	40015284		10009227	
450	35	3	10104872		10007322	
500	35	3	10026359		10030833	
510	35	3	10013104		10007325	
520	35	3	10020335		10041815	
530	35	3	10030684		10041816	
610	35	3	10031855		10007327	
630	35	3	40000604		10027187	
640	35	3	10007298		40002376	
710	35	3	10101966		10041817	
810	35	3	10021924		10007332	

60070 | Knives for system Brück

HL and cobalt quality

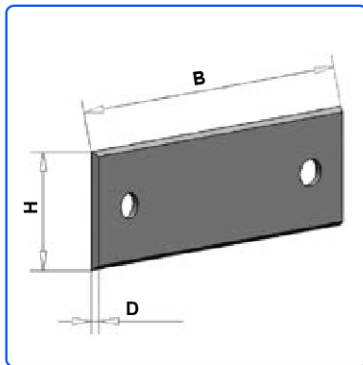

Application: HL = For soft wood
Cobalt = For soft wood and hard wood

Design: Ground ready for use
Disposable TOK = cannot be resharpened
Packing unit 20 pcs up to width = 260 mm
Packing unit 12 pcs from width = 300 mm
Prices are indicated per piece

Width mm	Height mm	Thickness mm	Order No. HL	Price [PG 02]	Order No. Kobalt	Price [PG 02]
60	18,6	1	10108727		10108729	
80	18,6	1	40012815		40002502	
100	18,6	1	40000634		40015677	
105	18,6	1	10102172		10102173	
110	18,6	1	10102176		10102175	
120	18,6	1	10025696		10102178	
130	18,6	1	10102026		40009494	
136	18,6	1	40009498		10102182	
150	18,6	1	40008623		10031019	
170	18,6	1	10102185		10102186	
180	18,6	1	40003509		10031397	
186	18,6	1	10102189		10102190	
190	18,6	1	10014486		10102192	
210	18,6	1	10014921		10102194	
230	18,6	1	40000637		40015079	
240	18,6	1	10102197		10102198	
250	18,6	1	10102200		10102201	
260	18,6	1	10014484		10029512	
300	18,6	1	40010793		10102203	
305	18,6	1	10102204		10102205	
310	18,6	1	10042387		10102207	
320	18,6	1	10100830		10102209	
350	18,6	1	10102210		10102211	
360	18,6	1	10102212		10102213	
400	18,6	1	40006550		10102214	
410	18,6	1	10018695		10102215	
420	18,6	1	10102216		10102217	
450	18,6	1	10015981		10102218	
460	18,6	1	10100975		10102220	
500	18,6	1	10102221		40005962	
510	18,6	1	10101684		40014627	
520	18,6	1	10102223		10102224	
530	18,6	1	10015980		10102225	
600	18,6	1	10102226		10102227	
610	18,6	1	10023744		10102228	
630	18,6	1	10101682		10102229	
640	18,6	1	40005413		10102230	
660	18,6	1	10102232		10102233	
710	18,6	1	10102234		10102235	
810	18,6	1	10102236		10102237	

60070 | Knives for system Brück

HL quality

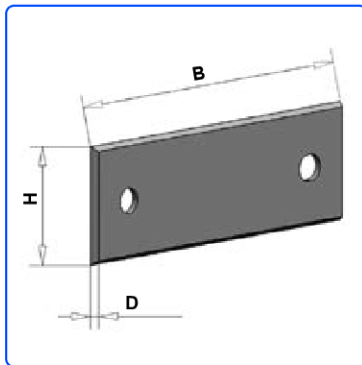

Application: For soft wood
 Design: Ground ready for use
 Disposable TOK = cannot be resharpended
 Packing unit 20 pcs up to width = 260 mm
 Packing unit 12 pcs from width = 300 mm
 Prices are indicated per piece

Width mm	Height mm	Thickness mm	Machine	Order No.	Price [PG 02]
205	18,6	1	HolzHer, Hema	40006562	
280	18,6	1	Mafell	40000639	
300	18,6	1	HolzHer, Hema	40000641	
300	18,6	1	Mafell	40000640	
320	18,6	1	Mafell	40008827	
350	18,6	1	HolzHer, Hema	40009406	



60030 | Knives for system Centrofix

Quality HS 18%

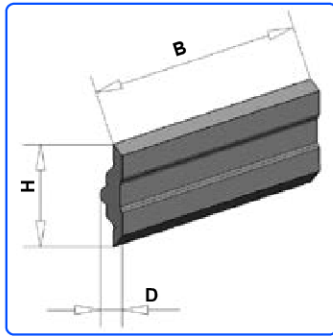

Application: HS 18 % = For soft wood and hard wood

Design: Ground ready for use
 Disposable TOK = cannot be resharpened

Packing unit 2 pcs
 Prices are indicated per piece

Available also in HW

Width mm	Height mm	Thickness mm	Order No.	Price [PG 02]
50	12	2,7	10042188	
60	12	2,7	10017434	
80	12	2,7	10042265	
100	12	2,7	40003708	
120	12	2,7	10042270	
130	12	2,7	10031777	
136	12	2,7	10042273	
150	12	2,7	10042274	
180	12	2,7	40010794	
190	12	2,7	10042276	
210	12	2,7	10042277	
230	12	2,7	10101712	
240	12	2,7	40006645	
310	12	2,7	10013238	
400	12	2,7	10024764	
410	12	2,7	40006200	
420	12	2,7	10024497	
430	12	2,7	10018410	
500	12	2,7	10103127	
510	12	2,7	10019888	
520	12	2,7	40007794	
530	12	2,7	40005756	
540	12	2,7	10100478	
600	12	2,7	40012730	
610	12	2,7	10100479	
630	12	2,7	10018811	
640	12	2,7	10042179	
810	12	2,7	10100480	

60030 | Knives for system Centrolock / Weinig

60070 | Quality HS 18 %, HW

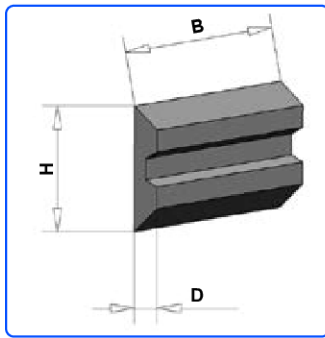

Application: HS 18 % = For soft wood and hard wood
 HW = For hard wood, laminated wood and panel material

Design: Ground ready for use
 TOK = can be resharpened
 M42 - black oxide coated
 Packing unit 2 pcs
 Prices are indicated per piece

Width mm	Height mm	Thickness mm	Order No. HS 18%	Price [PG 02]	Order No. HW	Price [PG 02]
20	16	3	10100634		10101141	
60	16	3	10100637		10101142	
80	16	3	10100639		10041559	
100	16	3	40011198		10101143	
130	16	3	40002379		40015446	
150	16	3	10100641		10041560	
170	16	3	10031241		10031688	
180	16	3	10100642		10101144	
190	16	3	10100643		10020595	
210	16	3	10101132		10101187	
230	16	3	10025405		10017355	
240	16	3	10101709		40015447	
260	16	3	10101134		10101188	
270	16	3	10101136		40016138	
310	16	3	10101139		10101189	
460	16	3	10101140		10101190	

60030 | Knives for system Terminus

Quality HS 18%

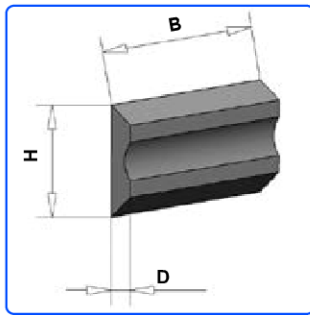

Application: HS 18% = For soft wood and hard wood

Design: Ground ready for use
 TOK = can be resharpened
 Packing unit 2 pcs
 Prices are indicated per piece
 Available also in HW

Width mm	Height mm	Thickness mm	Order No.	Price [PG 02]
50	14	2,5	10041818	
60	14	2,5	10041819	
80	14	2,5	10041821	
100	14	2,5	10016798	
110	14	2,5	10041822	
120	14	2,5	10026751	
130	14	2,5	40010764	
136	14	2,5	10041824	
140	14	2,5	40002272	
150	14	2,5	10041827	
160	14	2,5	10041828	
170	14	2,5	40003450	
180	14	2,5	40015637	
186	14	2,5	10041829	
190	14	2,5	10030863	
200	14	2,5	10041830	
210	14	2,5	10031772	
220	14	2,5	10041831	
230	14	2,5	40015602	
240	14	2,5	10030961	
250	14	2,5	10041832	
260	14	2,5	40010788	
270	14	2,5	40011993	
300	14	2,5	10041833	
310	14	2,5	10031773	
350	14	2,5	10041834	
360	14	2,5	10041835	
400	14	2,5	10041836	
410	14	2,5	40010787	
420	14	2,5	10041837	
510	14	2,5	10041838	
610	14	2,5	10041839	

60030 | Knives for system Tersa

60070 | Quality HW, HS and HS M42

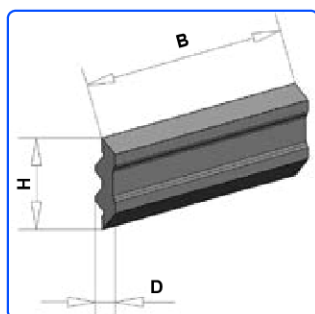

Application: Solid carbide = For hard wood, laminated wood and panel material
 HS = For soft wood and hard wood
 HS M42 = For soft wood

Design: Ground ready for use
 Disposable TOK = cannot be resharpened
 M42 - black oxide coated
 Packing unit 2 pcs
 Prices are indicated per piece

Width mm	Height mm	Thickness mm	Order No. HW	Price [PG 02]	Order No. HS	Price [PG 02]	Order No. HS M42	Price [PG 02]
60	10	2,3	40011475		10028436		10153532	
80	10	2,3	40000211		10028437		10153533	
100	10	2,3	10017832		10028438		10153534	
110	10	2,3	40009221		40008485		10153535	
120	10	2,3	10014494		10026611		10153536	
130	10	2,3	10015031		10014208		10153537	
150	10	2,3	40000215		40000148		10153538	
170	10	2,3	40000216		10024019		10153539	
180	10	2,3	40000217		40004210		10153540	
210	10	2,3	10015023		10031844		10153541	
230	10	2,3	40000220		40004211		10153542	
250	10	2,3	40000221		40000187		10153543	
260	10	2,3	40000222		10101520		10153544	
280	10	2,3	10101679		40015992		10153545	
300	10	2,3	10015024		10021300		10153546	
310	10	2,3	40006757		10103105		40012737	
350	10	2,3	40000227		10026483		10153547	
360	10	2,3	40000228		40000193		10153548	
400	10	2,3	10015022		10022144		10153549	
410	10	2,3	40006756		10023233		40012738	
420	10	2,3	10101870		40009757		10153550	
430	10	2,3	10101871		10016490		10153551	
450	10	2,3	40000232		40000197		10153552	
500	10	2,3	10018542		10016946		10153553	
510	10	2,3	10020306		10015656		10143759	
520	10	2,3	10024394		10100544		10153554	
530	10	2,3	40011354		40002744		10153555	
610	10	2,3	10101953		10022151		10153556	
630	10	2,3	10021972		10015180		40015615	
640	10	2,3	10014307		10100537		10143760	
710	10	2,3			10025157		10153557	
810	10	2,3			40008077		10153558	

60070 | Turn-over knives for Rali hand planer

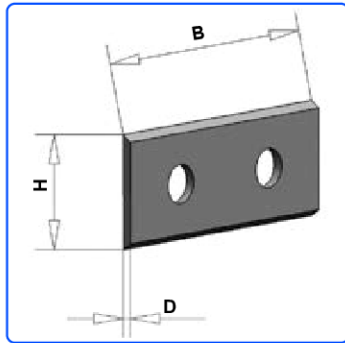
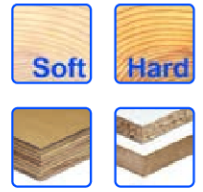

Application: HS 18 % = For soft wood and hard wood
HW = For hard wood, laminated wood and panel material

Design: Ground ready for use
Disposable TOK = cannot be resharpened
Packing unit 10 pcs
Prices are indicated per piece

Width mm	Height mm	Thickness mm	Quality	for Rali-Type	Order No.	Price [PG 02]
30	12	1	HS 18%	G30 Simshobel	10102248	
48	12	1	HS 18%	105 / 220	10102247	
48	12	1	HW	105 / 220	40000753	

Further qualities (hardness, bending strength) and dimensions available

63070 | HW turn-over knives 35°



Application: K05 = For hard wood, laminated wood and panel material
K01 = For panel material and plastic material

Design: Ground ready for use
Disposable TOK
= cannot be resharpened
Packing unit 10 pcs
Prices are indicated per piece

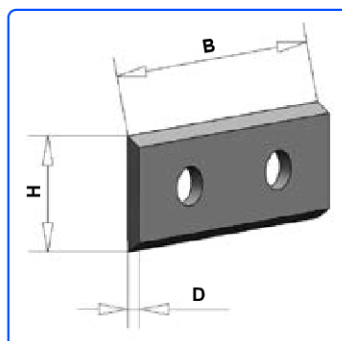

2 cutting edges (35°)

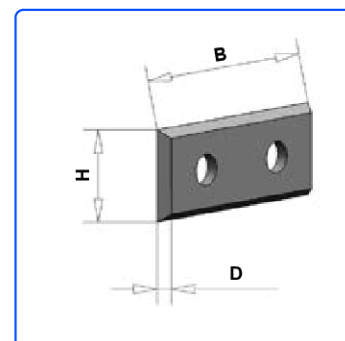

4 cutting edges (35°)

2 cutting edges (35°)

Width mm	Height mm	Thickness mm	Order No. K05	Price [PG 01]	Order No. K01	Price [PG 01]
7,5	12	1,5	10009449			
7,65	12	1,5	10009477			
9,6	12	1,5	10009480			
11,6	12	1,5	10009483			
15	12	1,5	10009455		10009492	
20	12	1,5	10009457		10022241	
25	12	1,5	40016017			
30	12	1,5	10009464		10009500	
40	12	1,5	10009466		10023095	
50	12	1,5	10009474		10009503	
60	12	1,5	10009476			
80	13	2,2	10009478			
100	13	2,2	10009481			
120	13	2,2	10009484			

4 cutting edges (35°)

Width mm	Height mm	Thickness mm	Order No. K05	PG	Price [PG 01]	Order No. K01	Price [PG 01]
12	12	1,5	10009450	02		40005307	
20	12	1,5	10009521	01		10102314	
30	12	1,5	10009523	01		10102315	
40	12	1,5	10009524	01			
50	12	1,5	10009525	01		10102316	
50	12	1,7				10009526	
60	12	1,5	10009527	01			

63070 | HW turn-over knives 45°

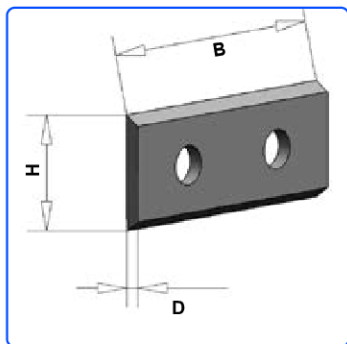

Application: K05 = For hard wood, laminated wood and panel material
K01 = For panel material and plastic material

Design: Ground ready for use
Disposable TOK = cannot be resharpened
Packing unit 10 pcs
Prices are indicated per piece

2 cutting edges (45°)

Width mm	Height mm	Thickness mm	Quality	Order No.	Price [PG 01]
15	12	1,5	K05	10022249	
20	12	1,5	K05	10019782	
30	12	1,5	K05	10018999	
40	12	1,5	K05	10022250	
50	12	1,5	K05	10022251	
60	12	1,5	K05	10022252	

63070 | HW wipers and spurs

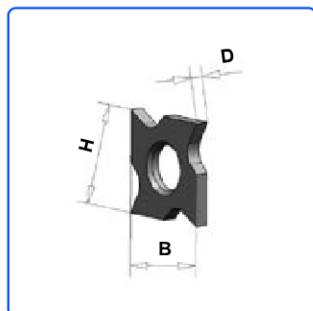

Standard-raker for grooving cutter head and adjustable grooving cutter head

Width mm	Height mm	Thickness mm	Quality	Order No.	Price [PG 01]
18	18	1,95	HW	10009494	
18	18	2,45	HW	10009495	
18	18	2,95	HW	10009496	

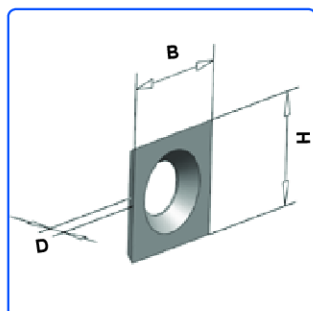

HW spurs, 4 cutting edges (30°- 35°)

Width mm	Height mm	Thickness mm	Quality	Clamping system	with chip breaker groove	Order No.	PG	Price
10,5	10,5	1,5	HW			10009482	01	
13,0	13,0	2,5	HW	Oppold		10018835	01	
13,6	13,6	2,0	HW		X	10013923	01	
14,0	14,0	1,2	HW	Holzher		10022232	01	
14,0	14,0	1,2	HW			10009452	01	
14,0	14,0	1,7	HW			10009454	01	
14,0	14,0	2,0	HW			10009453	01	
14,3	14,3	2,5	HW			10009520	02	
15,0	15,0	2,0	HW			10009493	01	
15,0	15,0	2,5	HW			40007373	01	
20,0	14,3	2,5	HW		X	10009522	01	
22,0	19,0	2,0	HW			10009497*	01	

* 3 cutting edges

63070 | HW turn-over knives



Application: HW = For soft wood, hard wood, laminated wood and panel material

Design: Ground ready for use
 Disposable TOK
 = cannot be resharpened
 Packing unit 10 pcs
 Prices are indicated per piece

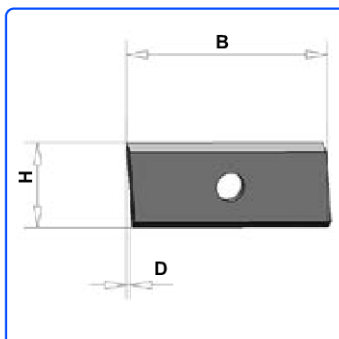

TOK with chamfer,
2 cutting edges

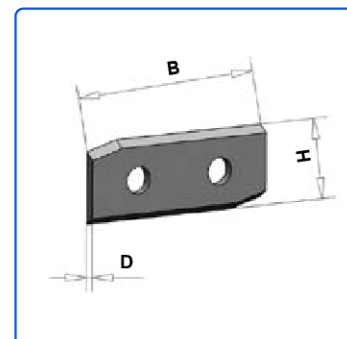

TOK with bevel,
2 cutting edges

TOK with chamfer, 2 cutting edges

Width mm	Height mm	Thickness mm	Quality	Bevel	Order No.	Price [PG 01]
30	12	1,5	HW	lhs	10022236	
30	12	1,5	HW	rhs	10020537	
50	12	1,5	HW	lhs	10022234	
50	12	1,5	HW	rhs	10022235	

TOK with bevel, 2 cutting edges

Width mm	Height mm	Thickness mm	Quality	Bevel	Order No.	Price [PG 01]
30	12	1,5	HW	lhs	10009462	
30	12	1,5	HW	rhs	10009463	
50	12	1,5	HW	lhs	10009472	
50	12	1,5	HW	rhs	10009473	

63070 | HW turn-over knives

With rounded edges and with pointed edges

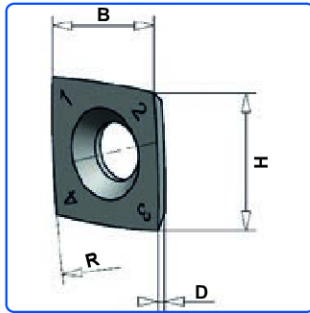
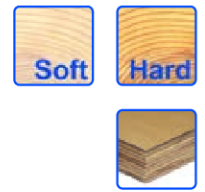

Application: To be applied in planer heads and jointing cutter heads
HW = For soft wood, hard wood and panel material

Design: Ground ready for use
Disposable TOK = cannot be resharpened
Packing unit 10 pcs
Prices are indicated per piece

With rounded edges

Width mm	Height mm	Thickness mm	Radius	Quality	Order No.	Price [PG 01]
15	15	2,5	50	HW	10102511	
15	15	2,5	115	HW	10149346	
15	15	2,5	150	HW	10152889	

With pointed edges

Width mm	Height mm	Thickness mm	Radius	Quality	Order No.	Price [PG 01]
15	15	2,5	50	HW	10152890	
15	15	2,5	100	HW	10152891	
15	15	2,5	150	HW	10152892	

63070 | HW turn-over knives

For system Versofix



Application: HW = For soft wood, hard wood, laminated wood and panel material

Design: Ground ready for use
Disposable TOK
= cannot be resharpened

Packing unit 10 pcs
Prices are indicated per piece

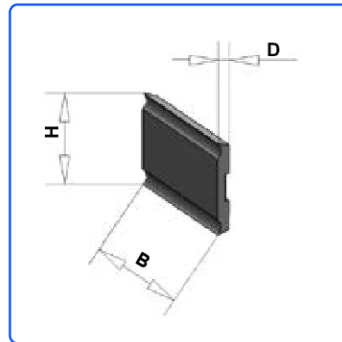

For System Versofix. With back groove non-coated [1661]

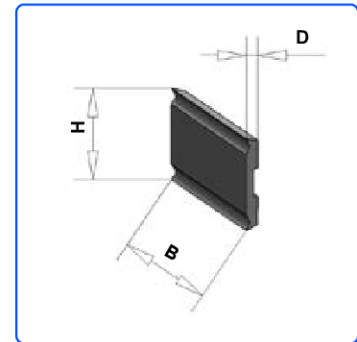

For System Versofix. With back groove TIN coated [1661]

For system Versofix. With back groove, TIN coated [1661]

Width mm	Height mm	Thickness mm	Design	Order No.	Price [PG 02]
20	5,5	1,1	without chamfer	10016255	
20	10,0	1,5	without chamfer	10102359	
30	6,5	1,1	without chamfer	10022273	
30	10,0	1,5	without chamfer	10021311	
50	6,5	1,1	without chamfer	10022274	
50	10,0	1,5	without chamfer	10021279	
50	10,0	1,5	with chamfer	10017542	

For system Versofix. With back groove, non-coated [1661]

Width mm	Height mm	Thickness mm	Design	Order No.	Price [PG 02]
20	10,0	1,5	without chamfer	10102446	
30	6,5	1,1	without chamfer	10102443	
30	10,0	1,5	without chamfer	10100711	
50	6,5	1,1	without chamfer	10102444	
50	10,0	1,5	without chamfer	40000676	
50	10,0	1,5	with chamfer	10102447	

63070 | HW turn-over knives

System Oppold, Hundegger, Weinmann, Weinig



Application: HW = For soft wood, hard wood, laminated wood and panel material

Design: Ground ready for use
 Disposable TOK = cannot be resharpened
 Packing unit 10 pcs
 Prices are indicated per piece

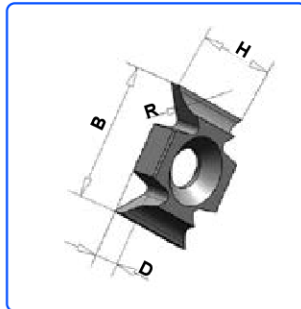

For system Oppold

Width mm	Height mm	Thickness mm	Quality	Order No.	Price [PG 02]
30	12	1,5	HW	10009547	
44,5	15	1,5	HW	10102357	

HW edge knives. System Oppold

Width mm	Height mm	Thickness mm	Edge	Quality	Order No.	Price [PG 02]
22	16	5	45°	HW	10109412	
22	16	5	R 1,5	HW	10022276	
22	16	5	R 2	HW	10022277	
22	16	5	R 2,5	HW	10022278	
22	16	5	R 3	HW	10107583	

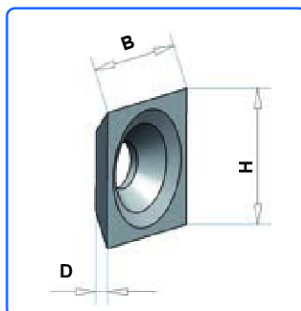

TOK. System Hundegger

Width mm	Height mm	Thickness mm	Quality	Order No.	Price [PG 02]
21	21	5,5	HW	10015491	

TOK. System Hundegger / Weinmann / Weinig

Width mm	Height mm	Thickness mm	Quality	Order No.	Price [PG 02]
17	17	2	HW	10014012	
19	19	2	HW	10017958	



Application: To be applied in window tools and profile tools
For soft wood, hard wood, laminated wood and panel material

Design: Ground ready for use
Disposable TOK = cannot be resharpended
Packing unit 1 pc
Prices are indicated per piece

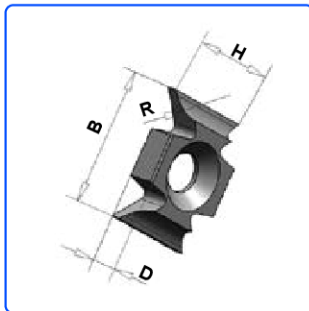

Edge knives for MEC feed

Width mm	Height mm	Thickness mm	Radius	Quality	Order No.	Price [PG 02]
16	22	5	45°	HW	10109412	
16	22	5	1,5	HW	10022276	
16	22	5	2,0	HW	10022277	
16	22	5	2,5	HW	10022278	
16	22	5	3,0	HW	10107583	
16	22	5	4,0	HW	40003967	
16	22	6	5,0	HW	10157339	



Application: HW = For soft wood, hard wood, laminated wood and panel material

Design: Ground ready for use
 Disposable TOK = cannot be resharpened

Packing unit 10 pcs
 Prices are indicated per piece

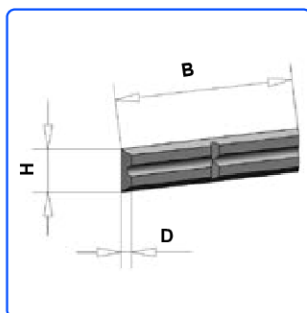

Mini TOK with back groove and cross groove, 4 cutting edges

Width mm	Height mm	Thickness mm	Quality	Order No.	Price [PG 01]
20	4,1	1,1	HW	10006964	
20	5,5	1,1	HW	10006965	
25	5,5	1,1	HW	10006966	
30	5,5	1,1	HW	10006967	
40	5,5	1,1	HW	10009507	
50	5,5	1,1	HW	10006968	

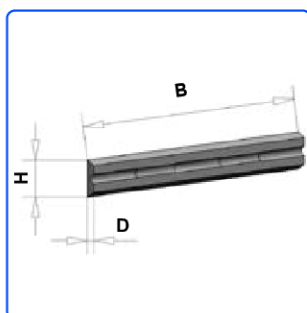

Mini TOK with back groove for portable planers, 2 cutting edges

Width mm	Height mm	Thickness mm	Quality	Order No.	Price [PG 01]
56,0	5,5	1,1	HW	10009513	
60,0	5,5	1,1	HW	10009514	
75,5	5,5	1,1	HW	10009515	
80,5	5,5	1,1	HW	10102061	
80,5	5,8	1,2	HW	10009516	
82,0	5,5	1,1	HW	10009517	
102,0	5,5	1,1	HW	10022256	

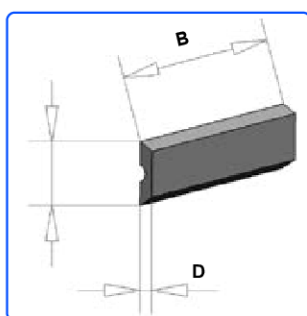

Mini TOK with face groove, 2 cutting edges

★ = polished

Width mm	Height mm	Thickness mm	Quality	Order No.	Price [PG 01]
7,7	8	1,5	HW	10022262	
9,7	8	1,5	HW	10101123	
11,7	8	1,5	HW	★ 10013991	
14,7	8	1,5	HW	★ 10013999	
19,7	8	1,5	HW	★ 10020269	
24,7	8	1,5	HW	★ 10022266	
30,0	8	1,5	HW	★ 10014024	
35,0	8	1,5	HW	★ 10022267	
40,0	8	1,5	HW	★ 10026542	
50,0	8	1,5	HW	★ 10022268	
60,0	8	1,5	HW	★ 10021809	
80,0	8	1,5	HW	★ 10022269	
100,0	8	1,5	HW	★ 10022270	
120,0	8	1,5	HW	★ 10022271	

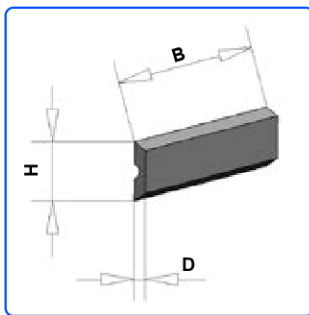

Mini TOK with face groove, 2 cutting edges

Width mm	Height mm	Thickness mm	Quality	Order No.	Price [PG 01]
12	5,5	1,1	HW	10009485	
20	5,5	1,1	HW	10009458	
30	5,5	1,1	HW	10009501	
40	5,5	1,1	HW	10009510	
50	5,5	1,1	HW	10009511	

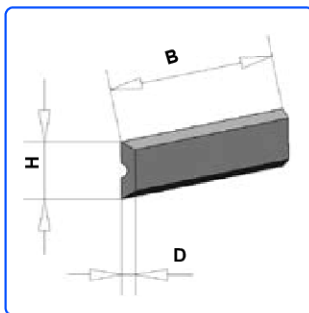

Mini TOK with face groove, 4 cutting edges

Width mm	Height mm	Thickness mm	Quality	Order No.	Price [PG 01]
20	5,5	1,1	HW	10009499	
30	5,5	1,1	HW	10009465	
40	5,5	1,1	HW	10009488	
50	5,5	1,1	HW	10009489	

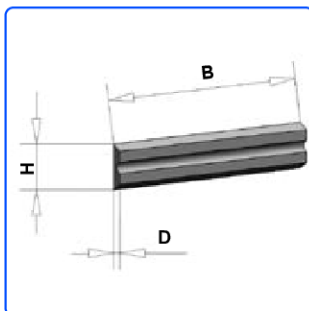

Mini TOK with back groove, 2 cutting edges

Width mm	Height mm	Thickness mm	Quality	Order No.	Price [PG 01]
12	5,5	1,1	HW	10009451	
20	5,5	1,1	HW	10009505	
30	5,5	1,1	HW	10009506	
40	5,5	1,1	HW	10009502	
50	5,5	1,1	HW	10009512	

Mini TOK with back groove, 4 cutting edges

Width mm	Height mm	Thickness mm	Quality	Order No.	Price [PG 01]
20	5,5	1,1	HW	40002439	
30	5,5	1,1	HW	10009509	
40	5,5	1,1	HW	40000665	
50	5,5	1,1	HW	40000662	



Application: For TOK rounding cutter heads
 Design: Ground ready for use
 Disposable TOK = cannot be resharpended
 Packing unit 10 pcs
 Prices are indicated per piece

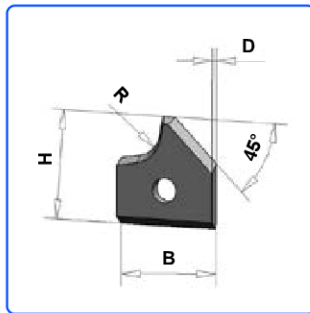

Fig.: Bevel - TOK left

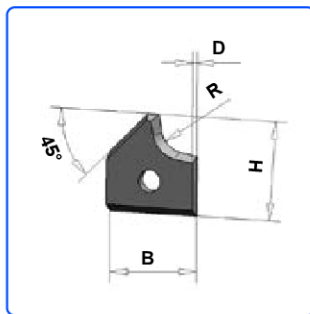
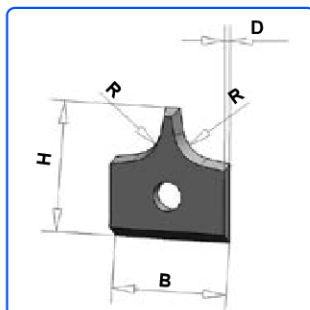

Fig.: Bevel - TOK right

Bevel TOK

Width mm	Height mm	Thickness mm	Radius mm	Quality	rhs/lhs	Order No.	Price [PG 02]
16	17,5	2	2 / 45°	HW	lhs	10105228	
16	17,5	2	2 / 45°	HW	rhs	10105235	
16	17,5	2	3 / 45°	HW	lhs	10041321	
16	17,5	2	3 / 45°	HW	rhs	10041322	
16	17,5	2	4 / 45°	HW	lhs	10105229	
16	17,5	2	4 / 45°	HW	rhs	10105236	
16	17,5	2	5 / 45°	HW	lhs	10041352	
16	17,5	2	5 / 45°	HW	rhs	10041353	
16	17,5	2	6 / 45°	HW	lhs	40009325	
16	17,5	2	6 / 45°	HW	rhs	40009324	
24	20	2	6 / 45°	HW	lhs	10105230	
24	20	2	6 / 45°	HW	rhs	10105238	
24	20	2	7 / 45°	HW	lhs	10105231	
24	20	2	7 / 45°	HW	rhs	10105239	
24	20	2	8 / 45°	HW	lhs	10105232	
24	20	2	8 / 45°	HW	rhs	10105240	
24	20	2	9 / 45°	HW	lhs	10105233	
24	20	2	9 / 45°	HW	rhs	10105241	
24	20	2	10 / 45°	HW	lhs	10105234	
24	20	2	10 / 45°	HW	rhs	10105242	

Double radius TOK



Width mm	Height mm	Thickness mm	Radius mm	Quality	Order No.	Price [PG 02]
16	17,5	2	2	HW	10009564	
16	17,5	2	3	HW	10009565	
16	17,5	2	4	HW	10009566	
16	17,5	2	5	HW	10042291	
24	20	2	6	HW	10010672	
24	20	2	7	HW	10041052	
24	20	2	8	HW	10010674	
24	20	2	9	HW	10010675	
24	20	2	10	HW	10010676	



Application: To be applied on edge banding machines
 Design: Ground ready for use
 Disposable TOK = cannot be reshaped
 Packing unit 1 pc
 Prices are indicated per piece

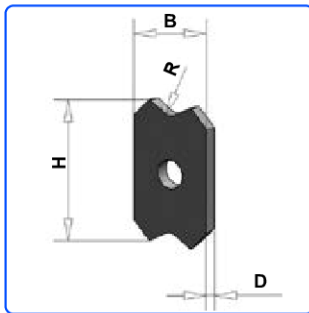

HW rounding scraper - standard

Width mm	Height mm	Thickness mm	Radius/chamfer mm	Quality	Order No.	Price [PG 02]
12	20	2	45°	HW	10010909	
12	20	2	0,8	HW	10010889	
12	20	2	1,0	HW	10010890	
12	20	2	1,5	HW	10041220	
12	20	2	2,0	HW	10040875	
12	20	2	2,5	HW	10010893	
12	20	2	3,0	HW	10010894	
12	20	2	3,5	HW	10010895	
12	20	2	4,0	HW	10010896	
12	20	2	4,5	HW	10010897	
12	20	2	5,0	HW	10010898	

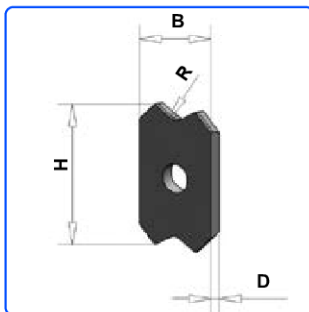

HW rounding scraper - anti stress whitening

Width mm	Height mm	Thickness mm	Radius/chamfer mm	Quality	Order No.	Price [PG 02]
12	20	2	1,5	HW	10041420	
12	20	2	2,0	HW	10105115	
12	20	2	3,0	HW	10041098	

62010 | HW radius and bevel turn-over knives



Application: Applied in TOK rounding cutters
 Design: Ground ready for use
 Disposable TOK = cannot be resharpener
 Packing unit 10 pcs
 Prices are indicated per piece

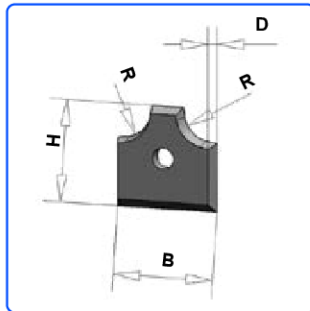

Width mm	Height mm	Thickness mm	Radius/bevel mm	Quality	Order No.	Price [PG 02]
12	12	1,5	2	HW	10027095	
12	12	1,5	3	HW	40010959	
12	12	1,5	4	HW	10111852	
12	12	1,5	45°	HW	10111904	
12	13	2,0	2	HW	10108816	
12	13	2,0	2,5	HW	10107782	
12	13	2,0	3	HW	10019565	

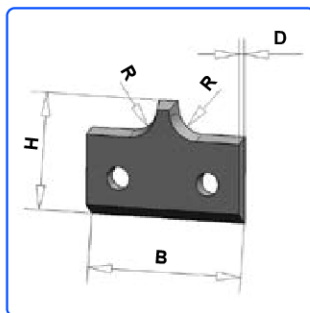

Width mm	Height mm	Thickness mm	Radius mm	Quality	Order No.	Price [PG 02]
30	17	2	5	HW	10027272	
30	17	2	6	HW	10111856	
30	17	2	7	HW	10111857	
30	17	2	8	HW	40003508	

62010 | HW radius turn-over knives



Application: Applied in TOK rounding cutters for edge banding machines

Design: Ground ready for use
 Disposable TOK = cannot be resharpened
 Packing unit 10 pcs
 Prices are indicated per piece

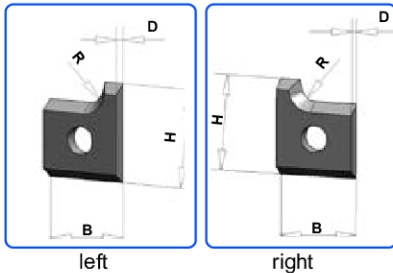

Width mm	Height mm	Thickness mm	Radius mm	Quality	rhs/lhs	Order No.	Price [PG 02]
12	14,5	2	2	HW	lhs	10111708	
12	14,5	2	2	HW	rhs	10100362	
12	14,5	2	2,5	HW	lhs	10016519	
12	14,5	2	2,5	HW	rhs	10016520	
12	14,5	2	3	HW	lhs	10106422	
12	14,5	2	3	HW	rhs	10106421	

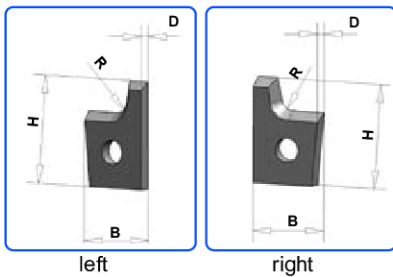

Width mm	Height mm	Thickness mm	Radius mm	Quality	rhs/lhs	Order No.	Price [PG 02]
12	18	2	2	HW	lhs	10014840	
12	18	2	2	HW	rhs	10014841	
12	18	2	3	HW	lhs	10023933	
12	18	2	3	HW	rhs	10023932	

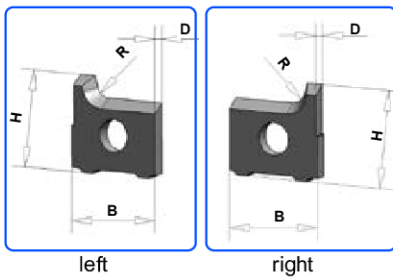

Width mm	Height mm	Thickness mm	Radius mm	Quality	rhs/lhs	Order No.	Price [PG 02]
15	14,5	2	2	HW	lhs	10042286	
15	14,5	2	2	HW	rhs	10042285	
15	14,5	2	2,5	HW	lhs	40007470	
15	14,5	2	2,5	HW	rhs	40007471	
15	14,5	2	3	HW	lhs	10016132	
15	14,5	2	3	HW	rhs	10016131	

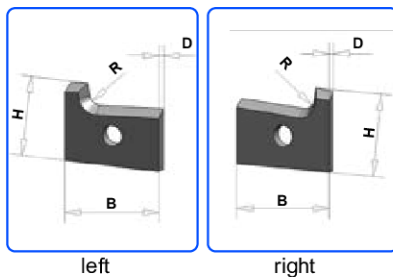

Width mm	Height mm	Thickness mm	Radius mm	Quality	rhs/lhs	Order No.	Price [PG 02]
19,6	15,2	2	2	HW	lhs	10101053	
19,6	15,2	2	2	HW	rhs	10101054	
19,6	15,2	2	3	HW	lhs	10042212	
19,6	15,2	2	3	HW	rhs	10042213	

62010 | HW radius turn-over knives

Double radius turn over knives



Application: For TOK rounding cutter heads
 Design: Ground ready for use
 Disposable TOK = cannot be resharpened
 Packing unit 10 pcs
 Prices are indicated per piece

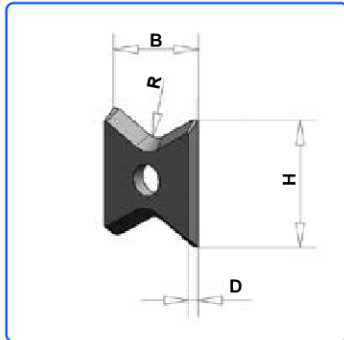

Turn-over knives 13 x 16 mm

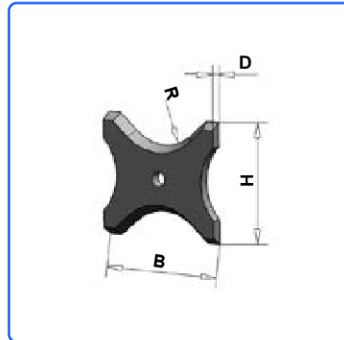

Turn-over knives 20 x 21 / 26 x 24 mm

Turn-over knives 13 x 16 mm

Width mm	Height mm	Thickness mm	Radius/bevel mm	Quality	Order No.	Price [PG 02]
13	16	2	2 / 5°	HW	10041187	
13	16	2	2 / 15°	HW	10111821	
13	16	2	3 / 5°	HW	10009550	
13	16	2	3 / 15°	HW	10111824	
13	16	2	4 / 5°	HW	10009551	
13	16	2	4 / 15°	HW	10111825	

Turn-over knives 20 x 21 / 26 x 24 mm

Width mm	Height mm	Thickness mm	Radius mm	Quality	Order No.	Price [PG 02]
20	21	2	5	HW	10009552	
20	21	2	6	HW	10009553	
20	21	2	7	HW	10009554	
20	21	2	8	HW	10009555	
26	24	2	9	HW	10009556	
26	24	2	10	HW	10009557	
26	24	2	11	HW	10009558	
26	24	2	12	HW	10009559	

62010 | Blanks with back tothing Super pack

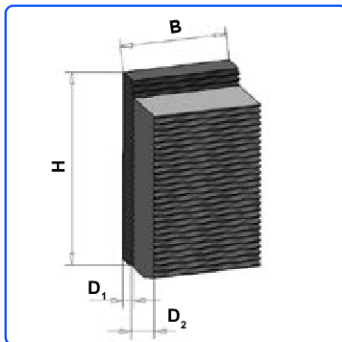
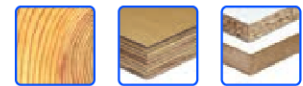

Application: For profile cutter heads with 90° back tothing. Knife thickness 10 mm
For hard wood, laminated wood and panel material
H = 38 mm: planing
H = 50 mm: PD max. 12 mm

Design: HW knife with back tothing to be applied with support plate
Unprofiled

Packing unit 1 pc
Prices are indicated per piece

Knives

Support plate

Width mm	Height mm	Thickness mm	Order No. Knife	Price [PG 02]		Height mm	Thickness mm	Order No. Support plate	Price [PG 02]
40	38	3,2	10141408			35	7,1	33014874	
50	38	3,2	33013989			35	7,1	33013990	
60	38	3,2	10130824			35	7,1	10130826	
80	38	3,2	10139613			35	7,1	33014322	
100	38	3,2	10121199			35	7,1	10116065	
120	38	3,2	10153039			35	7,1	10153057	
130	38	3,2	10153040			35	7,1	10116064	
150	38	3,2	10153041			35	7,1	33014175	
170	38	3,2	10141407			35	7,1	33014177	
180	38	3,2	10153042			35	7,1	10153059	
200	38	3,2	10153043			35	7,1	10153060	
210	38	3,2	33015151			35	7,1	10153061	
230	38	3,2	10153044			35	7,1	10153062	
310	38	3,2	10153045			35	7,1	10153063	
330	38	3,2	10153046			35	7,1	10153064	
40	50	3,2	10116661			47	7,1	33014118	
50	50	3,2	33014001			47	7,1	33014002	
60	50	3,2	33014125			47	7,1	33014126	
80	50	3,2	10153047			47	7,1	33014278	
100	50	3,2	10121421			47	7,1	10121422	
120	50	3,2	10153048			47	7,1	10153065	
130	50	3,2	10153049			47	7,1	10153066	
150	50	3,2	10153050			47	7,1	33015129	
170	50	3,2	33013980			47	7,1	33013979	
180	50	3,2	10153051			47	7,1	10153067	
200	50	3,2	10153052			47	7,1	10153068	
210	50	3,2	10153053			47	7,1	10153069	
230	50	3,2	10153054			47	7,1	10153070	
310	50	3,2	10153055			47	7,1	10153071	
330	50	3,2	10153056			47	7,1	10153072	

Super pack HW knives with support plate. Total thickness 10 mm

62010 | Blanks with back tothing Super pack

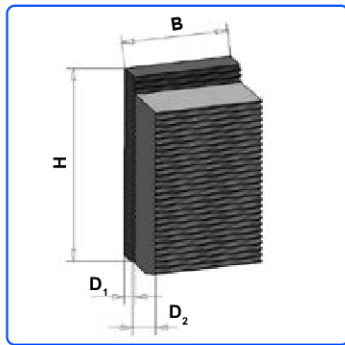

Application: For profile cutter heads with 90° back tothing. Knife thickness 10 mm
For hard wood, laminated wood and panel material
H = 60 mm: PD max. 23 mm

Design: HW knife with back tothing to be applied with support plate
Unprofiled
Packing unit 1 pc
Prices are indicated per piece

Knives

Support plate

Width mm	Height mm	Thickness mm	Order No. Knife	Price [PG 02]		Height mm	Thickness mm	Order No. support plate	Price [PG 02]
40	60	3,2	10121746			57	7,1	33012975	
50	60	3,2	10121745			57	7,1	10121747	
60	60	3,2	10116945			57	7,1	33012853	
80	60	3,2	33012875			57	7,1	33012877	
100	60	3,2	33011973			57	7,1	33014224	
120	60	3,2	10141656			57	7,1	10141657	
130	60	3,2	10142454			57	7,1	33012304	
150	60	3,2	10152834			57	7,1	33014225	
170	60	3,2	10152835			57	7,1	33012852	
180	60	3,2	10152836			57	7,1	10152843	
200	60	3,2	10152837			57	7,1	10152845	
210	60	3,2	10152838			57	7,1	10152846	
230	60	3,2	10152839			57	7,1	10152847	
310	60	3,2	10152841			57	7,1	10152849	
330	60	3,2	10152842			57	7,1	10152851	

Super pack HW knives with support plate. Total thickness 10 mm

Allocation: Knives - cutter head

D Cutter head mm	Height 40	Height 50	Height 60	Height 70
122	142	162	182	202
135	154	174	194	214
145	164	184	204	224
150	169	189	209	229
165	184	204	224	244
170	189	209	229	249
190	209	229	249	269

62030 | HS Blanks with back tothing

Thickness 5 mm

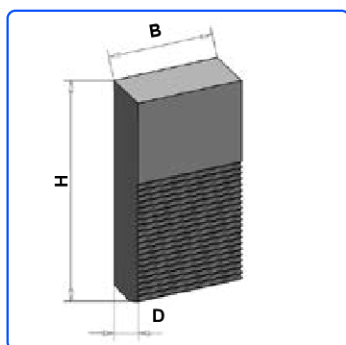

Application: For profile cutter heads with 90° back tothing. Knife thickness 5 mm
For hard wood, laminated wood and panel material
H = 27 mm: for planing
H = 38 mm: for planing

Design: HS knives, unprofiled
Packing unit 1 pc
Prices are indicated per piece

Height 27 mm

Width mm	Height mm	Thickness mm	Order No. Knife	Price [PG 02]
20	27	5,0	10153165	
30	27	5,0	10153167	
40	27	5,0	10153168	
50	27	5,0	10153169	
60	27	5,0	10153171	
70	27	5,0	10153172	
80	27	5,0	10153173	
90	27	5,0	10153174	
100	27	5,0	10153175	
110	27	5,0	10153176	
120	27	5,0	10153177	
130	27	5,0	10153178	
150	27	5,0	10153180	
170	27	5,0	10153181	
180	27	5,0	10153182	
190	27	5,0	10153183	
210	27	5,0	10153184	
230	27	5,0	10153185	
240	27	5,0	10153186	
650	27	5,0	10153187	

Height 38 mm

Width mm	Height mm	Thickness mm	Order No. Knife	Price [PG 02]
20	38	5,0	10153189	
30	38	5,0	10153190	
40	38	5,0	10153191	
50	38	5,0	10153192	
60	38	5,0	10153193	
70	38	5,0	10153194	
80	38	5,0	10153197	
90	38	5,0	10153198	
100	38	5,0	10153199	
110	38	5,0	10153200	
120	38	5,0	10153201	
130	38	5,0	10153202	
150	38	5,0	10153203	
170	38	5,0	10153204	
180	38	5,0	10153205	
190	38	5,0	10153206	
210	38	5,0	10153207	
230	38	5,0	10153208	
240	38	5,0	10153209	
650	38	5,0	10153210	

62030 | HS Blanks with back tothing

Thickness 5 mm

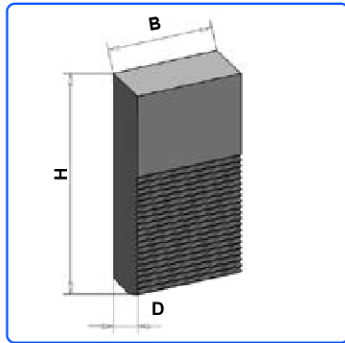

Application: For profile cutter heads with 90° back tothing. Knife thickness 5 mm
 For hard wood, laminated wood and panel material
 H = 45 mm
 H = 50 mm: PD max. 8 mm

Design: HS knives, unprofiled
 Packing unit 1 pc
 Prices are indicated per piece

Height 45 mm

Width mm	Height mm	Thickness mm	Order No. Knife	Price [PG 02]
20	45	5,0	10153221	
30	45	5,0	10153222	
40	45	5,0	10153224	
50	45	5,0	10153225	
60	45	5,0	10153226	
70	45	5,0	10153228	
80	45	5,0	10153229	
90	45	5,0	10153230	
100	45	5,0	10153231	
110	45	5,0	10153232	
120	45	5,0	10153233	
130	45	5,0	10153234	
150	45	5,0	10153235	
170	45	5,0	10153236	
180	45	5,0	10153237	
190	45	5,0	10153238	
210	45	5,0	10153239	
230	45	5,0	10153240	
240	45	5,0	10153241	
650	45	5,0	33015329	

Height 50 mm

Width mm	Height mm	Thickness mm	Order No. Knife	Price [PG 02]
20	50	5,0	10153242	
30	50	5,0	10153243	
40	50	5,0	10153244	
50	50	5,0	10153245	
60	50	5,0	10150676	
70	50	5,0	10153251	
80	50	5,0	10153252	
90	50	5,0	10153253	
100	50	5,0	10153255	
110	50	5,0	10153256	
120	50	5,0	10153257	
130	50	5,0	10153258	
150	50	5,0	10153259	
170	50	5,0	10153260	
180	50	5,0	10153261	
190	50	5,0	10153262	
210	50	5,0	10153263	
230	50	5,0	10153264	
240	50	5,0	10153265	
650	50	5,0	10153267	

Allocation: Knives - cutter head

D Cutter head mm	Height 40	Height 50	Height 60	Height 70
122	142	162	182	202
135	154	174	194	214
145	164	184	204	224
150	169	189	209	229
165	184	204	224	244
170	189	209	229	249
190	209	229	249	269

62030 | HS Blanks with back tothing

Thickness 8 mm, height 40 mm

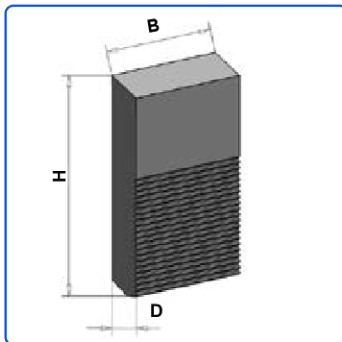

Application: For profile cutter heads with 90° back tothing. Knife thickness 8 mm
For solid wood
H = 40 mm: for planing

Design: Unprofiled blank to be applied in profile cutter heads with 90° back tothing. Please observe the cutter head's circle of rotation when the knives are inserted

Width mm	Height mm	Thickness mm	Quality	Order No. Knife	Price [PG 02]
40	40	8	HS	10152894	
50	40	8	HS	10152901	
60	40	8	HS	10152902	
70	40	8	HS	10152903	
80	40	8	HS	33015070	
90	40	8	HS	10152904	
100	40	8	HS	10152905	
110	40	8	HS	10152906	
120	40	8	HS	10152907	
130	40	8	HS	10152908	
150	40	8	HS	10152910	
170	40	8	HS	10152911	
180	40	8	HS	10152912	
200	40	8	HS	40015640	
210	40	8	HS	10152913	
230	40	8	HS	10152914	
260	40	8	HS	10152915	
650	40	8	HS	10152916	

Allocation: Knives - cutter head

D Cutter head mm	Height 40	Height 50	Height 60	Height 70
122	142	162	182	202
135	154	174	194	214
145	164	184	204	224
150	169	189	209	229
165	184	204	224	244
170	189	209	229	249
190	209	229	249	269

62030 | HS Blanks with back tothing

Thickness 8 mm, height 50 mm

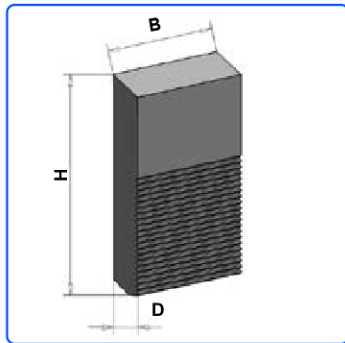

Application: For profile cutter heads with 90° back tothing. Knife thickness 8 mm

For solid wood
H = 50 mm: PD max. 12 mm

Design: Unprofiled blank to be applied in profile cutter heads with 90° back tothing. Please observe the cutter head's circle of rotation when the knives are inserted

Width mm	Height mm	Thickness mm	Quality	Order No. Knife	Price [PG 02]
40	50	8	HS	10152917	
50	50	8	HS	40001590	
60	50	8	HS	40001589	
70	50	8	HS	10144742	
80	50	8	HS	40001588	
90	50	8	HS	10152918	
100	50	8	HS	10152919	
110	50	8	HS	10152920	
120	50	8	HS	10101128	
130	50	8	HS	40005616	
150	50	8	HS	40007038	
170	50	8	HS	10152921	
180	50	8	HS	10152922	
200	50	8	HS	10152923	
210	50	8	HS	10152924	
230	50	8	HS	10134776	
260	50	8	HS	10152925	
650	50	8	HS	10119754	

Allocation: Knives - cutter head

D Cutter head mm	Height 40	Height 50	Height 60	Height 70
122	142	162	182	202
135	154	174	194	214
145	164	184	204	224
150	169	189	209	229
165	184	204	224	244
170	189	209	229	249
190	209	229	249	269

62030 | HS Blanks with back tothing

Thickness 8 mm, Height 60 mm

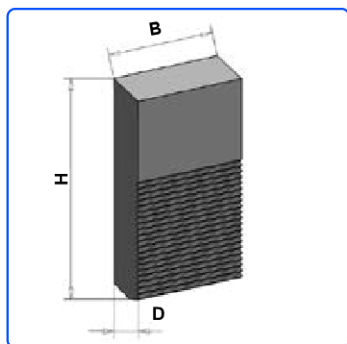

Application: For profile cutter heads with 90° back tothing. Knife thickness 8 mm

For solid wood
H = 60 mm: PD max. 18 mm

Design: Unprofiled blank to be applied in profile cutter heads with 90° back tothing. Please observe the cutter head's circle of rotation when the knives are inserted

Width mm	Height mm	Thickness mm	Quality	Order No. Knife	Price [PG 02]
40	60	8	HS	40001597	
50	60	8	HS	10152996	
60	60	8	HS	10025040	
70	60	8	HS	10153004	
80	60	8	HS	10153005	
90	60	8	HS	10153008	
100	60	8	HS	10153009	
110	60	8	HS	10153010	
120	60	8	HS	10153011	
130	60	8	HS	10153012	
150	60	8	HS	10133570	
170	60	8	HS	10153013	
180	60	8	HS	10105248	
200	60	8	HS	10153014	
210	60	8	HS	10153015	
230	60	8	HS	10105250	
260	60	8	HS	10153016	
650	60	8	HS	10119755	

Allocation: Knives - cutter head

D Cutter head mm	Height 40	Height 50	Height 60	Height 70
122	142	162	182	202
135	154	174	194	214
145	164	184	204	224
150	169	189	209	229
165	184	204	224	244
170	189	209	229	249
190	209	229	249	269

62030 | HS Blanks with back tothing

Thickness 8 mm, height 70 mm

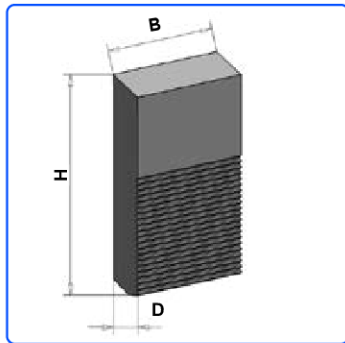

Application: For profile cutter heads with 90° back tothing
Knife thickness 8 mm

For solid wood
H = 70 mm: PD max. 30 mm

Design: Unprofiled blank to be applied in profile cutter heads with 90° back tothing. Please observe the cutter head's circle of rotation when the knives are inserted

Width mm	Height mm	Thickness mm	Quality	Order No. Knife	Price [PG 02]
40	70	8	HS	10153017	
50	70	8	HS	40001602	
60	70	8	HS	10101674	
70	70	8	HS	10153020	
80	70	8	HS	10153021	
90	70	8	HS	10153022	
100	70	8	HS	10153023	
110	70	8	HS	10153024	
120	70	8	HS	10153025	
130	70	8	HS	10153026	
150	70	8	HS	10153027	
170	70	8	HS	10145509	
180	70	8	HS	10153028	
200	70	8	HS	10153030	
210	70	8	HS	10153031	
230	70	8	HS	10153032	
260	70	8	HS	10153033	
650	70	8	HS	10145508	

Allocation: Knives - cutter head

D Cutter head mm	Height 40	Height 50	Height 60	Height 70
122	142	162	182	202
135	154	174	194	214
145	164	184	204	224
150	169	189	209	229
165	184	204	224	244
170	189	209	229	249
190	209	229	249	269