

HW Drills

ACUTE





Dowel HW drills. For CNC machines and automatic drilling machines. For drilling **wood, MDF, Chipboard** and plastic material. **negative** spurs and center point, **Very good finish**.

A106

4F

L-57



D	○/●	L	S
3	●	57	10
4	●	57	10
5	●	57	10
5.5	○	57	10
6	●	57	10
7	●	57	10
8	●	57	10
8.2	○	57	10
9	●	57	10
10	●	57	10
11	○	57	10
12	○	57	10
13	○	57	10
14	○	57	10
15	○	57	10
16	○	57	10

A107

4F

L-70



D	○/●	L	S
3	●	70	10
4	●	70	10
4.5	○	70	10
5	●	70	10
5.5	○	70	10
6	●	70	10
6.2	○	70	10
6.5	○	70	10
7	●	70	10
7.5	○	70	10
8	●	70	10
8.2	○	70	10
8.5	○	70	10
9	●	70	10
9.5	○	70	10
10	●	70	10
10.2	○	70	10
10.5	○	70	10
11	●	70	10
12	●	70	10
13	○	70	10
14	●	70	10
15	●	70	10
16	○	70	10



Dowel HW drills. For CNC machines and automatic drilling machines. For drilling **wood, MDF, Chipboard** and plastic material. **negative** spurs and center point, **Very good finish**.

D	○/●	L	S
5	●	77	10
5.5	○	77	10
6	●	77	10
7	●	77	10
8	●	77	10
8,2	○	77	10
10	●	77	10
12	○	77	10
14	○	77	10

A108

4F



L-77



D	○/●	L	S
5	●	85	10
6	●	85	10
7	●	85	10
8	●	85	10
9	●	85	10
10	●	85	10
12	●	85	10
14	○	85	10
15	○	85	10
16	○	85	10

A109

4F



L-85



D	○/●	L	S
5	●	105	10
6	●	105	10
7	○	105	10
8	●	105	10
9	○	105	10
10	●	105	10
11	○	105	10
12	●	105	10
13	○	105	10
14	○	105	10
16	○	105	10

A110

4F



L-105





Through hole HW drills. For CNC machines and automatic drilling machines . For drilling **wood, MDF, Chipboard and plastic material.** **negative** spurs and center point, **Very good finish.**

A201



L-57

4F



D	○/●	L	S
3	●	57	10
4	●	57	10
5	●	57	10
6	●	57	10
7	●	57	10
8	●	57	10
8,2	○	57	10
9	○	57	10
10	●	57	10
10,5	○	57	10
12	○	57	10
14	○	57	10

A202



L-70

4F



D	○/●	L	S
3	●	70	10
4	●	70	10
4.5	○	70	10
5	●	70	10
5.5	○	70	10
6	●	70	10
6.5	○	70	10
7	●	70	10
7.5	○	70	10
8	●	70	10
8.5	○	70	10
9	●	70	10
10	●	70	10
10.5	○	70	10
11	○	70	10
12	●	70	10
13	○	70	10
14	○	70	10
15	○	70	10

 Through hole HW drills. For CNC machines and automatic drilling machines. For drilling **wood, MDF, Chipboard and plastic material.** **negative** spurs and center point, **Very good finish.**

D	o/●	L	S
4	●	77	10
4,5	○	77	10
5	●	77	10
5,5	○	77	10
6	●	77	10
7	●	77	10
8	●	77	10
9	●	77	10
10	●	77	10
11	○	77	10
12	○	77	10



A203

L-77



D	o/●	L	S
5	●	85	10
5,5	○	85	10
6	●	85	10
7	●	85	10
8	●	85	10
9	●	85	10
10	●	85	10
11	●	85	10
12	●	85	10
13	○	85	10
14	○	85	10
15	○	85	10



A204

L-85



D	o/●	L	S
5	●	105	10
6	●	105	10
7	●	105	10
8	●	105	10
9	●	105	10
10	●	105	10
11	○	105	10
12	●	105	10
13	○	105	10
14	○	105	10
15	○	105	10



A205

L-105





HW hinge boring bits Z=2+2. For CNC machines and automatic drilling machines. For drilling **wood, MDF, Chipboard and plastic material. Very good finish.**

A301

L-57

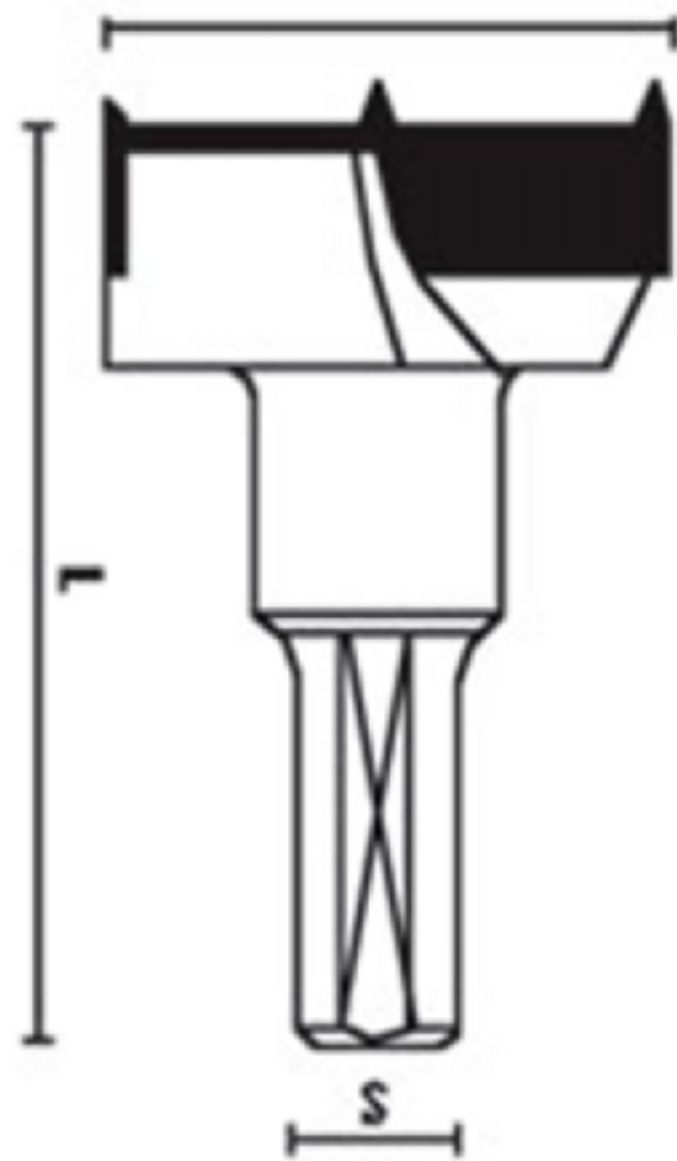

D	○/●	L	S
15	●	57	10
16	○	57	10
17	○	57	10
18	●	57	10
19	○	57	10
20	●	57	10
22	●	57	10
24	○	57	10
25	●	57	10
26	●	57	10
28	○	57	10
30	●	57	10
32	○	57	10
34	○	57	10
35	●	57	10
38	○	57	10
40	○	57	10

A302

L-70

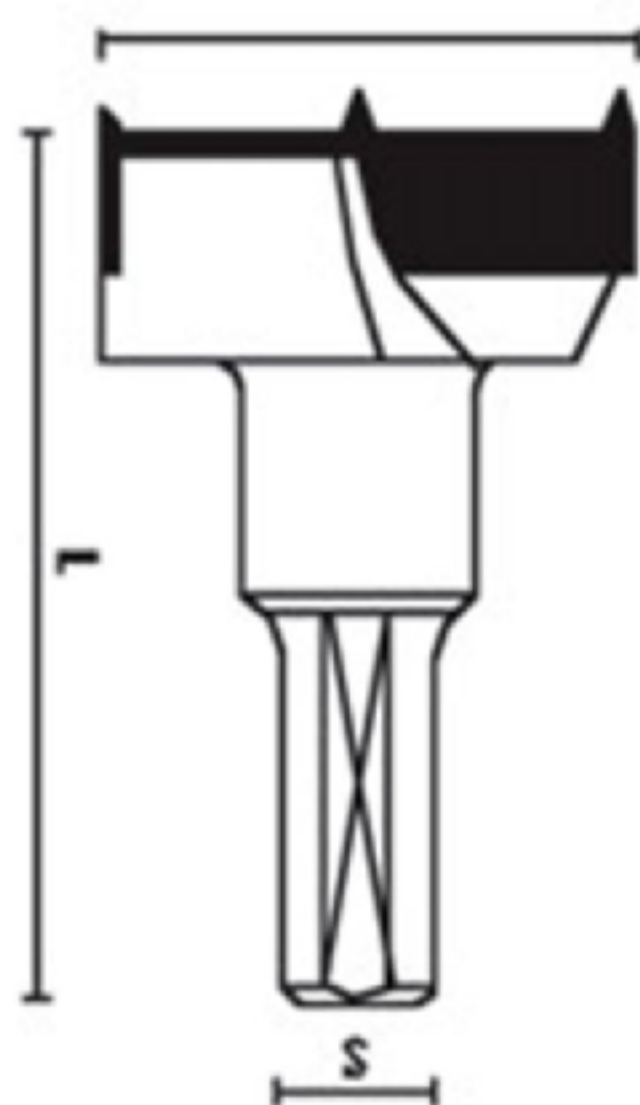

D	○/●	L	S
15	●	70	10
16	●	70	10
17	○	70	10
18	●	70	10
19	○	70	10
20	●	70	10
22	●	70	10
24	○	70	10
25	●	70	10
26	○	70	10
28	○	70	10
30	●	70	10
32	○	70	10
34	○	70	10
35	●	70	10
38	○	70	10
40	○	70	10

L-90 on request

 Solid carbide dowell drill bits. For CNC machines and automatic drilling machines . For drilling **wood, MDF, Chipboard** and **plastic material**. **Excelent finish.**

D	○/●	L	S
3	○	57	10
4	○	57	10
5	●	57	10
6	○	57	10
7	○	57	10
8	●	57	10
9	○	57	10
10	○	57	10

VHM L-57

A401



D	○/●	L	S
3	○	70	10
4	○	70	10
5	●	70	10
6	●	70	10
7	○	70	10
8	●	70	10
9	○	70	10
10	○	70	10

VHM L-70

A402



 Solid carbide through hole drill bits. For CNC machines and automatic drilling machines . For drilling **wood, MDF, Chipboard** and **plastic material**. **Excelent finish.**

D	○/●	L	S
3	○	57	10
4	○	57	10
5	●	57	10
6	○	57	10
7	○	57	10
8	●	57	10
9	○	57	10
10	○	57	10

VHM L-57

A403



D	○/●	L	S
3	○	70	10
4	○	70	10
5	●	70	10
6	●	70	10
7	●	70	10
8	●	70	10
9	○	70	10
10	○	70	10

VHM L-70

A404





Dowel HW drills type HP. For CNC machines and automatic drilling machines. For drilling **wood, MDF, Chipboard and plastic material**. **negative** spurs and center point, **Very good finish**.

A501 HP L-57



D	○/●	L	S
4	○	57	10
5	●	57	10
6	○	57	10
7	○	57	10
8	●	57	10
10	●	57	10
12	○	57	10

A502 HP L-70

D	○/●	L	S
4	○	70	10
5	●	70	10
6	○	70	10
7	○	70	10
8	●	70	10
10	●	70	10
12	○	70	10



Through hole HW drills type HP. For CNC machines and automatic drilling machines. For drilling **wood, MDF, Chipboard and plastic material**, **Very good finish**.

A601 HP L-57



D	○/●	L	S
4	○	57	10
5	●	57	10
6	○	57	10
7	○	57	10
8	●	57	10
10	●	57	10
12	○	57	10

on request

A602 HP L-70

D	○/●	L	S
4	○	70	10
5	●	70	10
6	○	70	10
7	○	70	10
8	●	70	10
10	●	70	10
12	○	70	10

 VHW hinge boring bits Z=2+2. For CNC machines and automatic drilling machines . For drilling **wood, MDF, Chipboard and plastic material. Very good finish.**

D	○/●	L	S
15	○	57	10x25
20	○	57	10x25
25	○	57	10x25
30	○	57	10x25
35	○	57	10x25

A604

VHM **HP** 57



D	○/●	L	S
15	●	70	10x25
20	○	70	10x25
25	●	70	10x25
30	○	70	10x25
35	●	70	10x25

A605

VHM **HP** 70



 HW countersinks Z=2 for drills. For CNC machines and automatic drilling machines . For drilling **wood, MDF, Chipboard and plastic material. Very good finish.**



d	L	S
3	60	10x30
4	60	10x30
5	60	10x30

A665 HM

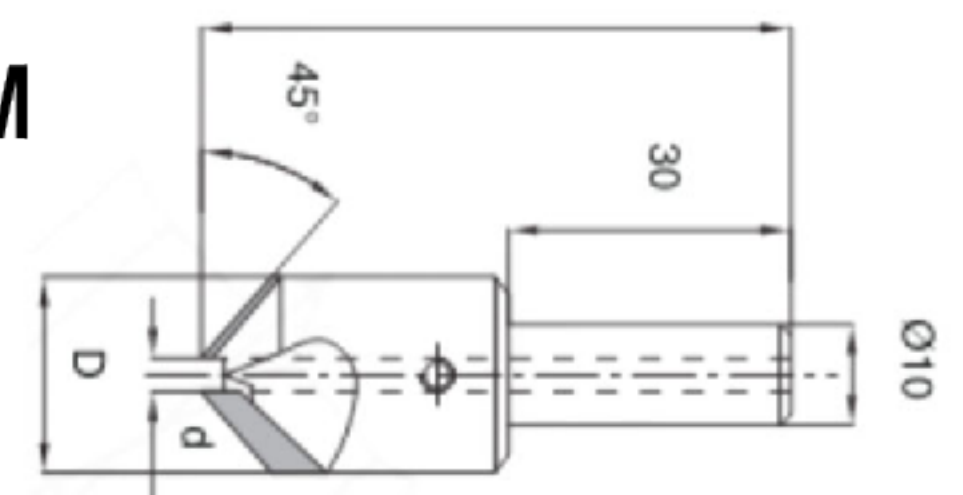

d	D
4	16
5	16
6	16
7	16
8	16
9	18
10	20
11	20
12	20

A698

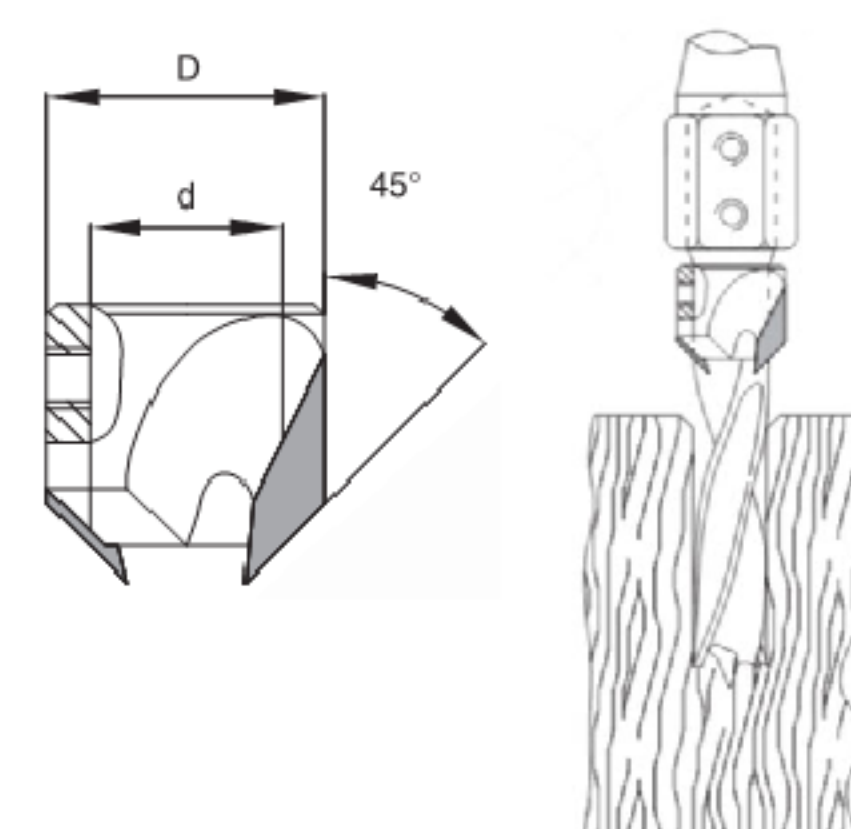



HW straight countersinks Z=2+2 for drills. For CNC machines and automatic drilling machines . For drilling **wood, MDF, Chipboard and plastic material. Very good finish.**

R100

Z=2+2

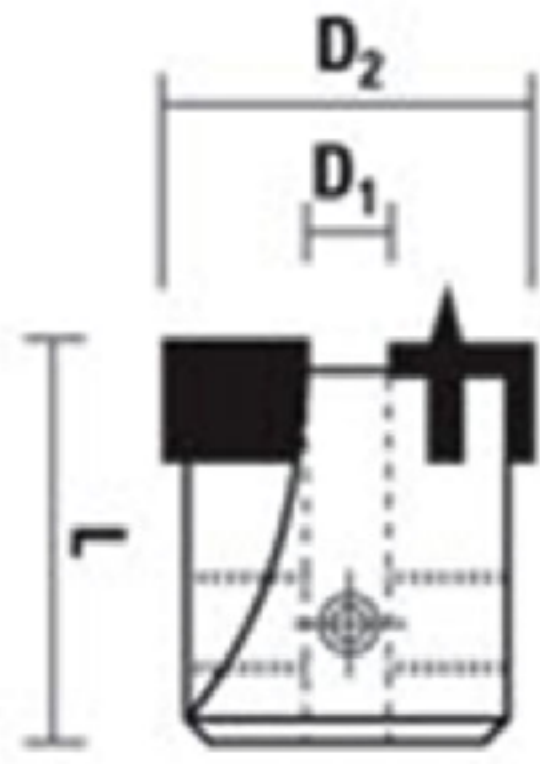

<i>D1</i>	<i>D2</i>	<i>L</i>
5	16	20
6	16	20
6	20	20
7	16	20
8	16	20
8	19	20
8	20	20
9	19	20
9	20	20
10	20	20
10	25	20
10	30	20
12	25	20
12	30	20

Drill holder

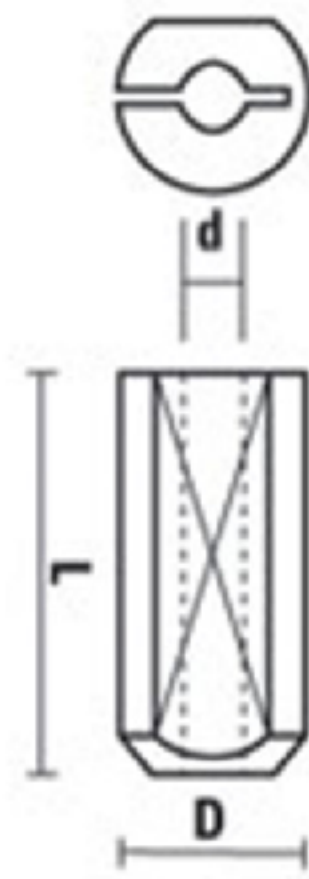

<i>D</i>	<i>L</i>
10	24
10	24
10	24
10	24
10	24
10	24
10	24
10	24
10	24

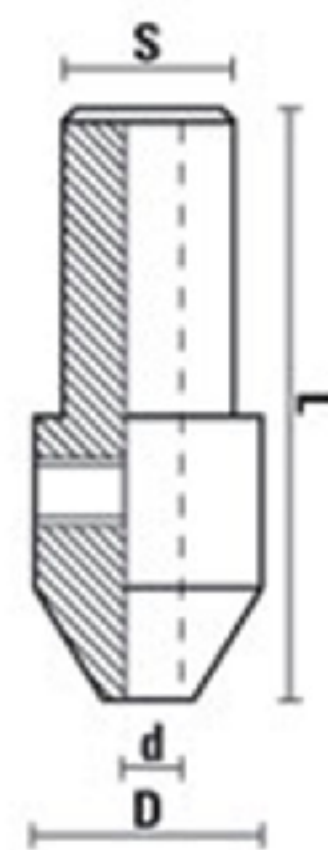

<i>D</i>	<i>L</i>	<i>S</i>
15	35	10
15	35	10
15	35	10
15	35	10
15	35	10
15	35	10
15	35	10
15	35	10
15	35	10
15	35	10